

Argent V50 Data Vault

The Ultimate Security Enclosure for 19-Inch Rack Equipment

ARGENT

Product Data Sheet



Argent V50 Data Vault

Typically a computer room or data centre is a secure facility with restricted access. Even with those access restrictions, data centres are a working environment. This can represent a security risk.

Business or Government departments often use hardware in a data centre that is highly sensitive. A second tier of physical security is an advantage. The patented Argent Data Vault is a simple, cost effective security enclosure that will protect hardware devices that are installed in a server rack. The Argent Data Vault allows your mission critical IT devices to be physically secure when installed in a server rack for maximum security and peace of mind.

FEATURES:

- Patented design
- Security enclosure for rack mounted hardware
- Can be installed inside any 19-inch server rack
- No external fasteners or screws when fitted
- Uses very little valuable RU space
- An extremely cost effective security system
- Has integrated ventilation
- Secure cable entry
- Depth is adjustable
- Included front & rear factory fitted key locks
- Option for client specified key lock
- Can be retro-fitted into an existing server rack already in use

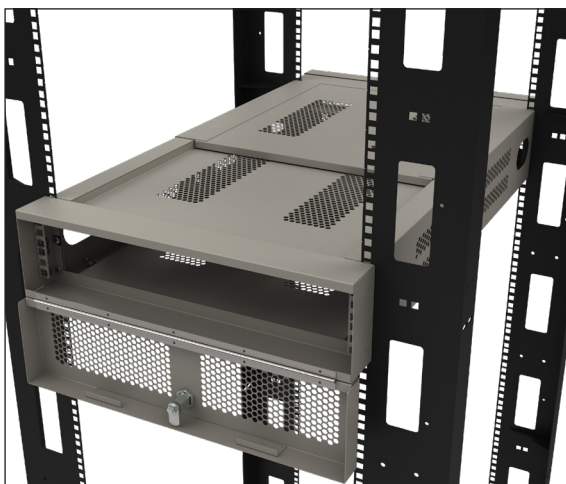
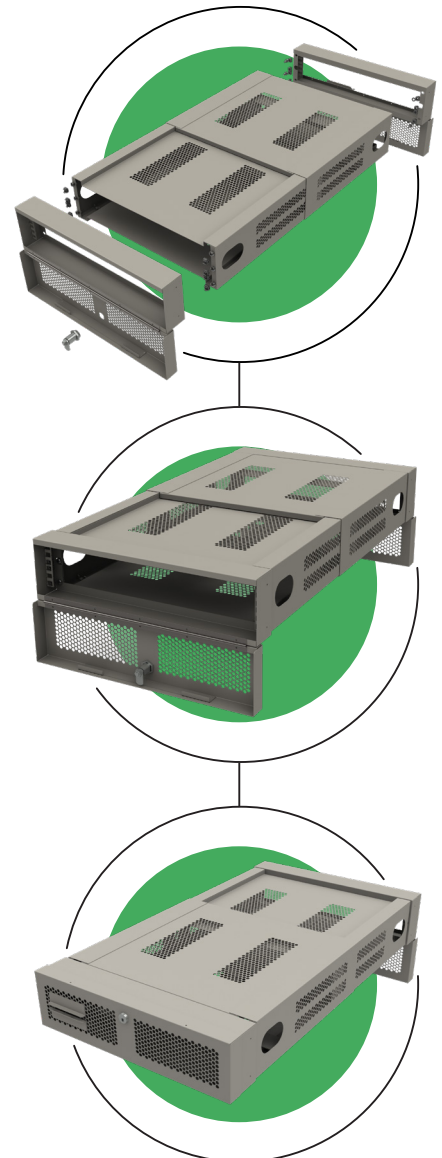

IT Hardware Security in Shared Offices

Argent V50 Data Vault will protect network equipment and servers in racks that are shared by two or more businesses. The retro fit feature allows users to move into an existing shared office and IT space. The V50 is a cost effective security solution for rack mounted hardware.

“I rent an office in a building where the comms room is shared with three other businesses. I don’t know who has access to it apart from my IT guys. I have a 2U server, PABX and a NAS device. The Argent V50 Data Vault provides a quick, cost effective security solution for my IT equipment.”



Argent V50 Data Vault

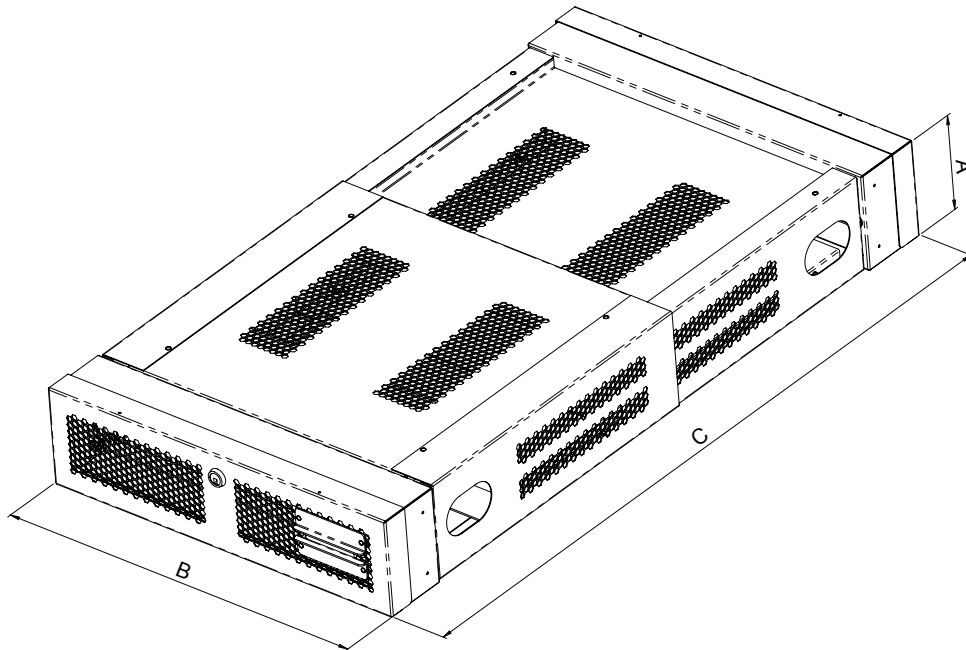

PART ID	DESCRIPTION	"A" MM HEIGHT	"B" MM WIDTH	"C" MM DEPTH
5ARG 902231-02SK	Argent V50 Data Vault — 2RU capacity includes Front & Rear keyed lock	130	493	675-975
5ARG 902231-04SK	Argent V50 Data Vault — 4RU capacity includes Front & Rear keyed lock	220	493	675-975
5ARG 902231-06SK	Argent V50 Data Vault — 6RU capacity includes Front & Rear keyed lock	310	493	675-975

Argent V50 Data Vaults are 100% patented, designed and manufactured in Australia by Wilson & Gilkes. The standard V50 Data vault colour is black.

Argent can offer alternative colours.

Specifications and dimensions are subject to change without notice.

10 SERIES

ARGENT 10 SERIES
Lite Server Cabinets



25 SERIES

ARGENT 25 SERIES
Network / Server Racks



40 SERIES

ARGENT 40 SERIES
Open Data Rack / Lab Rack



50 SERIES

ARGENT 50 SERIES
SCEC Class B & Class C
Server racks



V 50 DATA VAULT
PATENTED, IN RACK SECURITY



DATA CAGES
MODULAR SYSTEM



WALL MOUNTED RACKS



Australian Design & Manufacturing

Wilson & Gilkes opened its doors in the post-WWII economic reconstruction period. Since that time 75 years ago, the company has seen dramatic manufacturing, economic and social changes. In those early years it would have been almost impossible to imagine Wilson & Gilkes using automated laser technology to perform complex, precise metal cutting to produce Argent server racks.

Even with the assistance of world class manufacturing equipment, Wilson & Gilkes believes in the quality of its people to achieve flexible manufacturing solutions to achieve optimum results for Argent customers. The company employs qualified staff including Industrial Designers, Mechanical Engineers, Electricians, Sheetmetal trades, Fitters and Machinists, Toolmakers, Powder Coaters and Welders.

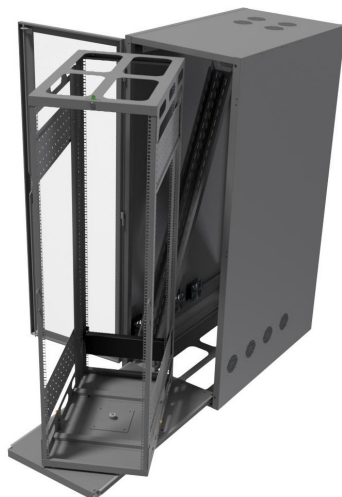
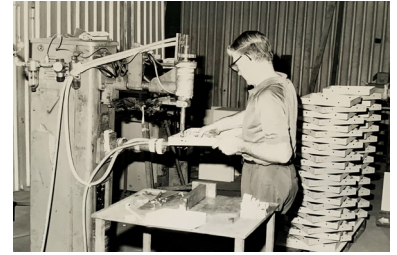

ARGENT DESIGN SERVICE

Argent server racks are used by Sydney Trains, and other large infrastructure and defence projects. Our team received a national corporate client's verbal concept for a rack that would incorporate integrated internal glide rails and a swivelling base. After successful prototypes and testing, Argent has now supplied over 400 of these racks that are in use everyday across Australia.

Argent has a team of industrial designers with years of storage system manufacturing experience. 3D images and drawings can be provided to assist with a solution that will meet your needs.



ARGENT MANUFACTURING, FABRICATION & ASSEMBLY

From design concept to finished product, every step in the process is managed in-house by Wilson & Gilkes.

AS 9001 ACCREDITED QUALITY SYSTEM

Argent is totally committed to an externally accredited, globally recognised quality system. We conduct spot quality checks in the manufacturing facility every day. The Wilson & Gilkes QA system works to create a better organisation for our clients and our staff.

